

# VACUUM PUMP OPERATING INSTRUCTIONS

In order to make the best use of your investment, familiarize yourself with the new features and operating instructions before starting pump. Routine care and maintenance of your vacuum pump will give you years of reliable service.

## FEATURES

- An air passage prevents pump oil from returning to contaminate vacuum vessel and pipeline after the pump stops.
- A built-in device eliminates oil mist and an oil-gas separator at the air exhaust outlet takes care of oil contamination in the air exhaust.

## 2 STAGE (DUAL VOLTAGE CAPABILITY)

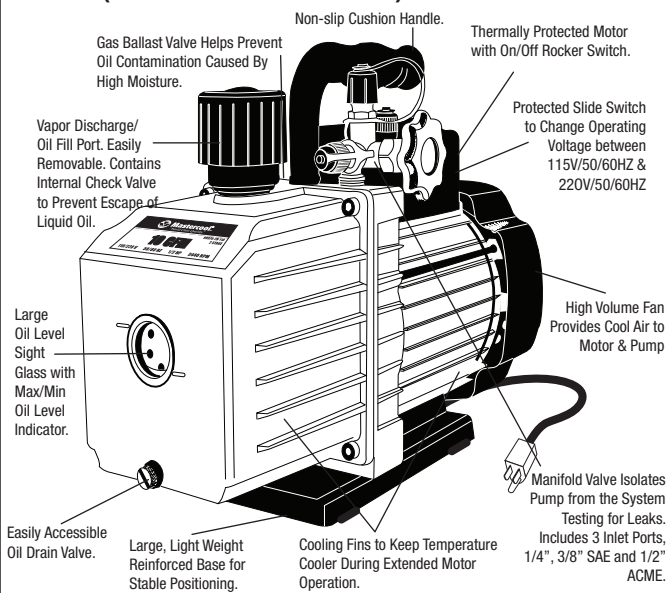

## 1 STAGE

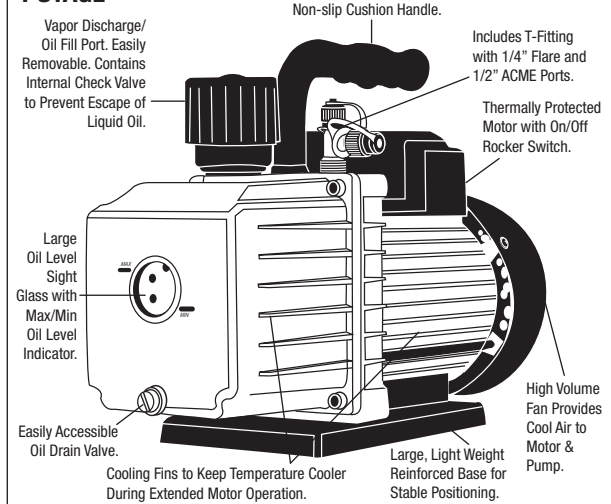

- Specially designed for low temperature and low voltage conditions to guarantee normal starting in winter;  $\geq 41^{\circ}\text{F}$  ( $\geq 5^{\circ}\text{C}$ ) temperature and  $\pm 10\%$  rated voltage.
- Pump runs with extremely high ultimate vacuum and low noise.

EACH VACUUM PUMP HAS BEEN FACTORY TESTED FOR CFM AND MICRON PERFORMANCE.



**DO NOT ATTEMPT TO OPERATE WITHOUT USING OIL!!!**

**Use oil specifically refined for Deep Vacuum Pumps. Use of oil not refined for Deep Vacuum Pumps and/or operating with contaminated oil will void warranty.**



**WARNING!**



**WEAR SAFETY GLASSES**

## 1. OIL FILL

This vacuum pump has been tested at the factory and shipped with only trace amounts of oil. OIL MUST BE ADDED BEFORE OPERATING! Failure to add oil will damage cartridge and void warranty!

- a. Make sure the oil drain valve located below the front casing is closed before attempting to add oil.
- b. Remove the rubber cap from the top of pump. (DO NOT USE DURING OPERATION)  
Unscrew oil fill port.
- c. Slowly add oil until oil level rises to the top of the Oil Level Line. Do not overfill with oil!
- d. Replace oil fill port.

### OIL CAPACITY:

3 CFM	1 Stage	13.5 OZ / 400 ML	3 CFM	2 Stage	13.5 OZ / 400 ML
6 CFM	1 Stage	15.2 OZ / 450 ML	6 CFM	2 Stage	13.5 OZ / 400 ML
10 CFM	2 Stage	19.3 OZ / 570 ML			

## 2. CHECKING OIL LEVEL

- a. Open the gas ballast valve (small brass fitting located next to the handle) one turn. Do not remove! (AVAILABLE ON 2 STAGE PUMPS ONLY)
- b. Start pump and run with intake port capped for about two minutes. Observe the oil level with the pump running. The oil level in the sight glass should be even with the level line.
- c. If the level is low, open the intake port and run pump for 15 seconds, stop pump and observe oil level again. Add a small amount of oil as needed.

## 3. GAS BALLAST VALVE (2 STAGE MODELS)

The gas ballast valve must be partially opened for the first part of the evacuation procedure. After about two minutes close the valve and continue the evacuation procedure to reach ultimate vacuum. Failure to close the valve during high vacuum operation will result in poor vacuum performance.

During the first stages of evacuation, vapors are highly concentrated. Unfortunately, some vapors will condense into a liquid and mix with the oil, thus reducing the oil's ability to produce a deep vacuum. The GAS BALLAST VALVE emits a controlled amount of dry air into the pump during compression to minimize condensation and keep oil relatively clean during the first part of the evacuation. Periodically remove the Gas Ballast Valve Needle and clean or replace the O-ring. Clean mating surfaces and lightly coat with vacuum pump oil before securely retightening.

## 4. CHANGING OIL

In order to reach the deep vacuum required, your vacuum pump needs clean, moisture-free oil during evacuation. Dirty oil becomes a mixture of corrosive acids and water that effects the pump's ability to pull a deep vacuum. Left sitting in the pump, this sludge will rust and erode internal surfaces shortening the pump's life.

Care should be taken to avoid contact of oil with skin or eyes. OIL MAY BE HOT! Used oil should be properly disposed of in a leakproof corrosive-resistant container according to local regulations.

- a. After every evacuation, while the pump is warm and oil is thin, take a small sample of oil from the drain port.
- b. If the oil is contaminated, drain the oil by placing the pump on a level surface and opening the oil drain valve. Catch the waste oil in a container and properly dispose of it.
- c. If the pump has been sitting for more than one month, the oil is considered contaminated

regardless of appearance and should be changed as outlined above.

d. To add oil, close drain, remove the oil fill cap and fill to the Oil Level Line with fresh oil.

## 5. INTAKE CONNECTIONS

Replace all caps and finger-tighten. Do not use caps with damaged or missing O-rings and always store vacuum pump with capped ports to prevent dirt and moisture contamination.

## 6. PUMP MOTOR

The PUMP and OIL must be above 30°F (1°C). The line voltage must be equal to the rating on the motor nameplate  $\pm 10\%$ . Normal operating temperature is approximately 160°F (71°C), which is HOT to the touch! Line voltage and ambient temperature will affect the normal operating temperature. Your vacuum pump is designed for continuous duty and will run for extended periods without overheating. The motor has an automatic resetting overload protection feature. If the motor will not restart the pump after shut-off, it may have opened the thermal protection. Disconnect the pump from the system, wait about 15 minutes for the motor to cool down and then try again.



### WARNING:

- 1) Do not evacuate combustible, explosive or poisonous gases.
- 2) Do not evacuate gases that corrode metal or react chemically with pump oil.
- 3) The temperature of evacuated gas shall not exceed 176°F (80°C) and ambient temperature shall be 41°F ~ 140°F (5°C ~ 60°C).
- 4) Do not operate without oil.
- 5) Do not touch the machine's hot surface during operation.
- 6) Do not block air outlet.

### CAUTION:

To reduce the danger of electric shock, keep the pump indoors and do not expose to rain.

### DANGER:

- 1) With a grounding socket the operating voltage is rated  $\pm 10\%$ ; Receptacle shall be well grounded, or else electric shock may be caused. Should power cord or plug require repair or replacement, do not connect grounded wire to any flat adapter connector. If its surface is green, with or without yellow stripe, the insulation wire is grounding wire. If you cannot fully understand grounding instructions and have doubt whether correct grounding is made, check with a professional electrician or service man. Do not change the structure of attached adapter connector.
- 2) When pulling out power plug, make sure to pull the plug rather than the wire.
- 3) Do not place heavy matter on power wire or let power wire be squeezed.
- 4) Do not use broken plug or socket.
- 5) Do not pull out power plug with wet hand.
- 6) Do not pull out, insert power plug or turn on power switch where flammable gases may be present.

## PUMP COMPONENTS

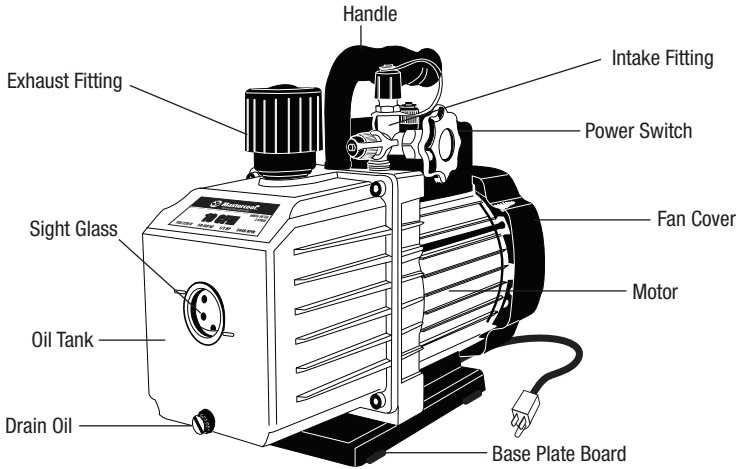

## RETURNING A PUMP

Please fax a request for a return authorization number to 973-252-2455. This applies to both warranty and non-warranty service!

Pumps returned for service without a return authorization number will not be accepted.

In your fax, include your NAME, ADDRESS and PHONE NUMBER along with a detailed explanation of the problem. We will contact you (i.e. your phone number) to discuss your problem and determine if you have to return your pump. If you have to return your pump, we will issue you an RMA #. Then, please follow the instructions below.

- Drain oil, cap all ports and place tape over the exhaust cap. If you fail to do this, your pump will not be accepted and it will be returned!!!
- Use the original shipping box and inserts if available. Shipping damages are impossible to claim on used machinery.

## LIMITED WARRANTY INFORMATION

The Vacuum Pumps are warranted against defects in material and workmanship for a period of one year. This warranty does not cover failure due to abuse, improper usage, or progressive wear and tear. Warranty becomes valid to the original owner and is effective on the purchase date. WARRANTY SERVICE IS PROVIDED THROUGH THE FACTORY ONLY.

Please contact the service department toll free for parts, service concerns, or to obtain a return authorization number for warranty repair.